

INSTRUCTION MANUAL

MODEL # 6590HK18, 6590RK18

SERIAL # _____



SPECIFICATIONS & GUIDELINES

*IMPORTANT:

READ ENCLOSED MANUALS BEFORE OPERATING YOUR COMPRESSOR

1. OIL TYPE TABLE

Temp.	0 - 40°	40° & above
NON-DETERGENT Straight Weight Recommended	10 WT	30 WT

*For maximum performance and service life, we recommend using ROLAIR Premium Quality Air Compressor Oil

2. EXTENSION CORD TABLE

Extension Cord Length	Motor 1/2 and 3/4 HP Minimum Wire Size	Motor 1, 1-1/2 and 2 HP Minimum Wire Size
Up to 25 Ft.	14 Ga.	12 Ga.
25-50 Ft.	12 Ga.	10 Ga.
50-100 Ft.	10 Ga.	8 Ga.

- The warranty on the motor will be **NULL** and **VOID** if a failure occurs and inspection proves a current deficiency.
- The **PRESSURE SWITCH** and/or pilot unloader valve are set at factory for maximum efficiency. **DO NOT** alter setting. Adjusting either will **VOID** the warranty.
- Engine RMP's (High – Low Settings) are factory set for maximum efficiency. Adjusting RPM's above factory specifications voids warranty.
- ALWAYS** shut off the engine's fuel line before transporting a gas powered air compressor. If left open, gas will seep past the needle/seat in carburetor, mix with the oil in the engine's crankcase, and foul out the spark plug. Replacement of spark plug and oil change will not be covered under warranty.

PLEASE NOTE: Refer to the enclosed engine owner's manual for additional operating information



PORTABLE AIR COMPRESSOR OWNER'S MANUAL

WARNING 
**COMPRESSOR DISCHARGE AIR MAY CONTAIN HYDROCARBONS AND OTHER
CONTAMINANTS! DO NOT USE DISCHARGE AIR FOR BREATHING!**

PARTS

Genuine ROLAIR replacement parts are sold nationwide through a network of authorized dealers and service centers. Please contact the dealership where your air compressor was purchased or our factory Customer Service Department if you need help troubleshooting, obtaining parts, or locating an authorized ROLAIR service representative.

- To order replacement parts:
1. Give compressor model number
 2. Give compressor serial number
 3. Name of part
 4. Part number
 5. Quantity required

RECORD OF PERTINENT INFORMATION

Make a permanent record of the model and serial number of your new air compressor here. You'll save time and expense by including this reference information when requesting service or replacement parts.

Place & Date of Purchase	Volts
Model	HZ
Serial #	HP

With the tank gauge at 0 PSI and air line(s) disconnected, close drain valve(s) and record the amount of time it takes to build tank pressure on the space provided. Periodically test your air compressor against this pump-up time to determine if it is operating correctly. If time test is considerably off, contact your local ROLAIR representative to arrange service.

	From 0 to _____ *PSI	From 0 to _____ *PSI
Date	Min Sec	Date Min Sec



TABLE OF CONTENTS

Introduction and Definitions of Safety Warnings-----	2
Safety Warnings – Risk of Asphyxiation & Bursting-----	3
Safety Warnings – Risk of Electrocution, Shock, Explosion, & Fire-----	3
Safety Warnings – Risk of Moving Parts, Burns, & Lifting-----	4
Safety Warnings – Risk of Propelled Objects, Unsafe Operation, and Damage----- To Compressor or Property	4
Identification of System Controls-----	5-6
Pre-Start Checklist-----	7
Operation-----	8
Maintenance-----	9-10
Troubleshooting-----	11
Guarantee-----	12

INTRODUCTION



Congratulations on the purchase of your new ROLAIR air compressor!

With over 50 years experience building ROLAIR air compressors specifically designed for the professional, Associate Engineering Corporation has earned a reputation for providing a product unsurpassed in quality and reliability. We are committed to continuing this tradition by analyzing and adapting to the changing needs and rigorous demands of your industry. You can depend on ROLAIR because they are built to last.

This manual was compiled for the benefit of the operator. Do not use or allow anyone else to use your air compressor until this manual is read and all safety/operating instructions are understood. By reading and following the instructions contained in this manual, you can achieve years of trouble free service from your new air compressor. If you have any additional safety or operating questions after reading this manual, please contact your distributor or our customer service department. Do not remove or paint over any of the warning decals attached to the compressor.

Definitions – Safety Warnings

Safety symbols are used throughout this manual to alert you to potentially hazardous situations. The following definitions describe the level of severity for each signal word.

-  **DANGER:** Indicates an imminently hazardous situation which, if not avoided, WILL result in death or serious injury.
-  **WARNING:** Indicates a potentially hazardous situation which, if not avoided, COULD result in death or serious injury.
-  **CAUTION:** Indicates a potentially hazardous situation which, if not avoided, MAY result in minor or moderate injury or damage to the air compressor.



⚠ WARNING







The engine exhaust from this product contains chemicals known to the State of California to cause cancer, birth defects or other reproductive harm.

⚠ WARNING







Do not start, operate or service machine until you read and understand operator's manual. Failure to do so could result in serious injury.

SAFETY WARNINGS

READ AND UNDERSTAND ALL SAFETY WARNINGS BEFORE USING AIR COMPRESSOR

Hazard Level	Potential of Hazard	How to Avoid Hazard
 Risk of Asphyxiation	Serious injury or death may occur from inhaling compressed air. The air stream may contain carbon monoxide, toxic vapors, or solid particles.	Never inhale compressed air directly from the pump, receiver, or from a breathing device connected to the air compressor.
	Sprayed materials such as paint, stucco, insecticides, solvents, etc. contain harmful vapors and poisons that may cause serious injury or death if inhaled.	Operate compressor only in a well-ventilated area. Use a respirator device and follow the manufacturer's recommendations for their spray equipment. Keep compressor at least 25 feet away from spray equipment.
	Serious injury or death may occur if the exhaust from gas-powered small engines is inhaled. Engine exhaust fumes contain poisonous, carbon monoxide which is odorless and colorless.	Operate gas-powered compressors only in a well-ventilated area. Avoid inhaling engine exhaust fumes, and never run a small gas-powered engine in a closed building or confined area without adequate ventilation.
 Risk of Bursting	Serious injury or death may occur from an air tank explosion if the air tanks are not properly maintained or if modifications, alterations or repairs are attempted to the air receivers.	Drain air tanks daily or after each use. Never drill into, weld, patch or modify the air tanks. If a leak develops, replace the tank immediately or replace the entire compressor.
	Serious injury or death may occur if modifications are made to the pilot unloader valve, pressure switch, safety relief valve or other components that control the tank pressure.	Never make adjustments to the components that control tank pressure. Do not make alterations to the factory operating pressure settings. Check operation of the safety valve on a regular basis and never operate without a factory approved safety valve.
	Serious injury may occur if accessories or attachments are operated above the manufacturer's recommended pressure ratings, causing them to explode or fly apart.	Do not use air tools or attachments before reading the owner's manual to determine the maximum pressure recommendations. Never exceed the manufacturer's maximum allowable pressure ratings. Do not use compressor to inflate small low pressure objects such as toys.
  Risk of Electrocution or Electrical Shock	Serious injury or death could occur if the air compressor is not properly grounded.	Always plug compressor into a properly grounded outlet which provides correct voltage, proper grounding and adequate fuse protection.
	Electrical shock may occur if compressor is not properly operated.	Never operate air compressor in wet conditions or outdoors when it's raining. Do not allow electric cords to lay in water. Do not operate with damaged power cord or with protective electrical covers removed. Do not touch plug with wet hands. Do not pull on electric cord to disconnect from the outlet.
	Serious injury or death may occur if electrical repairs are attempted by unqualified personnel.	Any electrical repairs or wiring performed on this compressor should only be performed by authorized service personnel in accordance with the National and Local Electric Codes.
  Risk of Explosion or Fire	Serious injury or death may result from normal electrical sparks that occur within the motor and/or pressure switch.	Always operate compressor in a well-ventilated area free of combustible materials, gasoline, flammable solvents or vapors. Always locate compressor at least 20 feet away from work area if spraying flammable materials.
	Serious injury may occur if a fire is caused by overheating due to inadequate ventilation or restrictions to any of the compressors ventilation openings.	Never place objects against or on top of an air compressor. Always operate air compressor at least 18" away from any wall or obstruction. Always operate in a clean, dry and well-ventilated area.
	Serious injury or death may occur from a fire or explosion if spilled gas or vapors come in contact with hot engine parts and ignite.	Never attempt to fill the gas tank while the engine is hot or running. Add fuel outdoors in a well-ventilated area. Do not fill gas tank near lit cigarettes or near other sources of ignition.

SAFETY WARNINGS (con't)

 Risk from Moving Parts	<p>Serious injury may occur from moving parts such as belts, pulleys, flywheels or fans if they came in contact with you or your clothing.</p>	<p>Never operate the air compressor without protective belt guards installed. Replace damaged protective covers or guards immediately.</p>
	<p>An electric air compressor with automatic controls can restart at any time and cause bodily injury when least expected.</p>	<p>Always unplug air compressor and drain air tanks completely before attempting any repairs or performing maintenance. Never allow children or adolescents to operate air compressor.</p>
	<p>Serious injury may occur if repairs are attempted with damaged, missing or removed protective guards, shrouds or missing covers.</p>	<p>All repairs to the air compressor should be made only by authorized or trained service personnel.</p>
 Risk of Burn	<p>Serious burn injuries could occur from touching exposed metal parts such as the compressor head, copper/braided discharge lines and engine exhaust muffler during operation, and even after compressor is shut down for sometime.</p>	<p>Never touch any of the exposed metal parts during operation and for an extended period of time after the air compressor has shut down. Do not attempt maintenance on the unit until it has been allowed to completely cool.</p>
 Risk of Injury from Lifting	<p>Serious injury can result from attempting to lift an object that is too heavy.</p>	<p>Always obtain assistance from others before attempting to lift any object that is too heavy for one person.</p>
 Flying Objects	<p>Serious injury may occur from loose debris being propelled at high speeds from the compressed air stream.</p>	<p>Always wear OSHA required "287" safety glasses to protect the eyes during operation of the air compressor. Never point the air stream or tools at any point of your body, other people or animals.</p> <p>Always turn off the air compressor and drain tank pressure completely before attempting maintenance or attaching air tools.</p>
 Warning Risk of Unsafe Operation	<p>Serious injury or death may occur to you or others if air compressor is used in an <u>unsafe</u> manner.</p>	<p>Review and understand all instructions and warnings in your owner's manual. Know how to stop the air compressor. Do not operate until you are thoroughly familiar with all of the controls. Do not operate the compressor if fatigued or under the influence of alcohol or drugs. Stay alert while operating the compressor and pay close attention to the task at hand.</p>
 Caution Risk of Damage to Air Compressor or Property	<p>Failure to transport or operate the air compressor properly may result in major repair expenses. Oil leaks will damage carpets, painted surfaces, flooring and other items.</p>	<p>Check oil levels daily and maintain proper oil levels. Always run compressor in a level, secure position that keeps it from tipping or falling during use. Do not operate without an air filter or in a corrosive environment.</p> <p>Always transport in a level position and use protective mats to keep truck beds clean, etc. Check drain bolts regularly and do not overfill machinery with oil.</p>

Please note that this product may not be equipped with a spark arresting muffler. If the compressor is operated around flammable materials or agricultural crops, brush, forests, and grasslands an approved spark arrestor must be installed, maintained and in good working order. An approved spark arrestor is legally required in the State of California under sections 4442 and 4443 of the California Public Resources Code Statute section 130050.

This product contains chemicals, including lead, known to the state of California to cause cancer, birth defects, and other reproductive harm. Always wash hands after handling this product.

SYSTEM CONTROLS

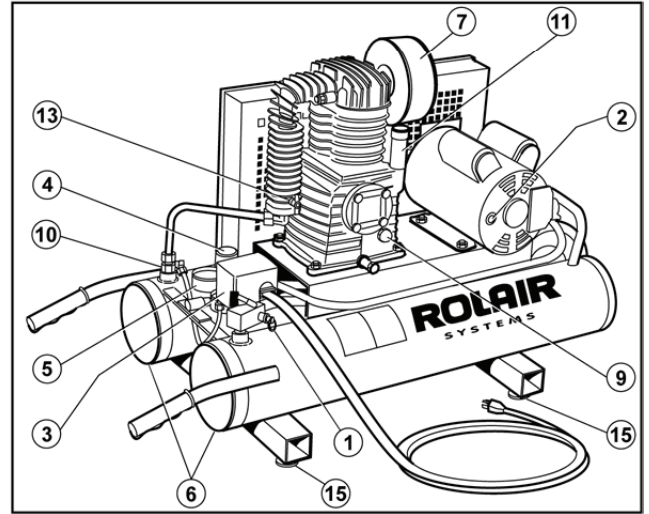
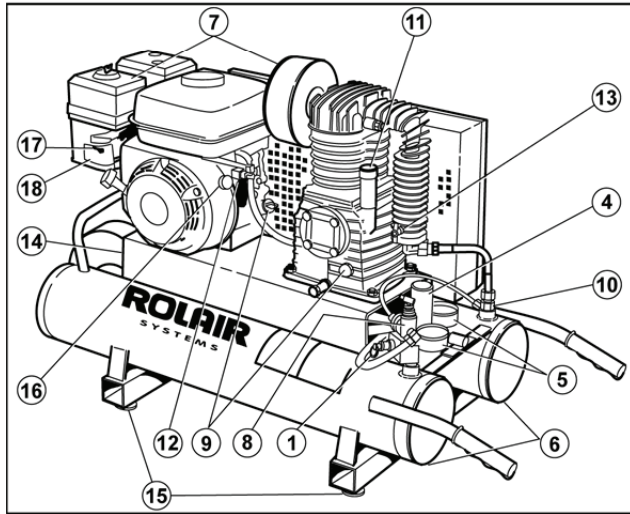
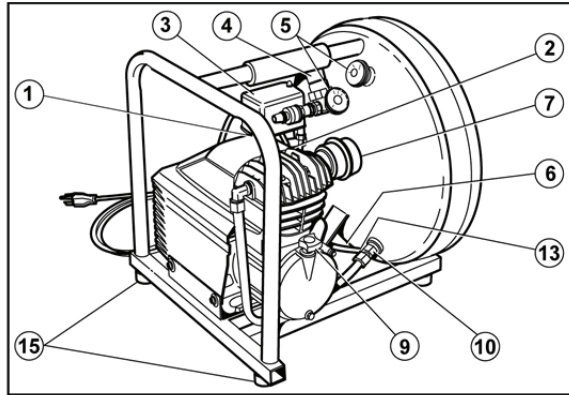

(1) SAFETY-RELIEF VALVE Every ROLAIR air compressor is equipped with a safety-relief valve which is designed to discharge tank pressure at a predetermined setting when a systems failure occurs. Check the safety valve periodically by pulling on the ring only when the tank pressure is completely drained. The spring loaded valve should move freely within the safety valve body. An inoperable safety valve could allow an excessive amount of tank pressure to build causing the air tank to catastrophically rupture or explode.



Do not tamper with or attempt to eliminate the safety relief valve.

(2) MANUAL OVERLOAD / MOTOR RESET Every ROLAIR electric air compressor is built with manual overload protection. If the motor overheats, the overload sensor will *trip* the reset button to protect the motor. If this occurs, please allow the motor to cool for approximately five minutes. Locate and push in the reset button. The use of an undersized or excessive length of extension cord may be the cause of overheating. Re-evaluate the power source and gauge/length of extension cord being used. (Refer to chart on page 8)

(3) PRESSURE SWITCH Most electric air compressors are operated by the use of a pressure switch. Always make sure the lever is in the "Off" position before plugging in the power cord. By moving the lever to the "On/Auto" position, the compressor will start and stop automatically within the settings of the pressure switch which are typically 105 – 130 PSI. Do not attempt to stop the compressor by unplugging the power cord. To stop, simply move the lever to the "Off" position. The lever operates a relief valve that dumps off head pressure and allows the compressor to restart without load the next time it is used.

(4) REGULATOR – WORKING PRESSURE To adjust the output/line pressure, simply lift up on the regulator adjustment knob and rotate clockwise to increase working pressure or counterclockwise to decrease. Push adjustment knob back down to lock in setting. Never exceed the manufacturer's maximum allowable pressure rating of the tool being used or item being inflated.

(5) PRESSURE GAUGE(S) Typically, most compressors are designed with a gauge to measure tank or storage pressure and another gauge attached to the regulator that indicates output or working pressure.

(6) DRAIN VALVE(S) One or more drain valves are installed to allow moisture to be drained on a daily basis from the compressor storage tank(s). Open drains carefully and slowly to prevent scale, rust, or debris from becoming expelled at a high rate of speed.

(7) AIR INTAKE FILTER Air intake filters are installed to prevent foreign matter from entering the engine or compressor pump. Check intake elements on a regular basis and either clean or replace as needed. Warm soapy water or low compressed air may be used to clean the elements. Check intake canisters or elbow components for cracks or broken seals and replace if structural problems are found.

SYSTEM CONTROLS

(con't)

(8) PILOT-UNLOADER VALVE A pilot-unloader valve is used on all gas-powered units and can be used on electric air compressors to operate in a continuous manner. When the storage tank reaches the top pressure setting of the pilot valve, the air being compressed is discharged to atmosphere instead of into the storage tank. When the tank pressure drops to the low pressure setting of the pilot valve, the compressed air will be redirected to the air tank. Do not attempt to replace the pilot valve without first draining the tank pressure completely. See Figure 3 for adjustment and fine-tuning instructions. Do not adjust above the following factory recommendations.

Classification	Pressure Setting
Direct Drive Compressor	105-130 PSI
I-Stage Compressor	110-135 PSI
II-Stage Compressor	130-150 PSI

(9) SIGHT GAUGE/DIPSTICK Prior to daily operation, make a habit of checking the oil level of the compressor pump and engine (if compressor is gas powered). Every direct-drive hand-carry air compressor has a dipstick to help check and maintain the proper oil level. The dipstick also functions as a crankcase vent. Never operate a direct-drive unit without the factory supplied dipstick. Our belt-driven air compressors are equipped with a sight gauge to make the daily task of checking the oil level easier. Always maintain the oil level to read 2/3 full on the sight gauge.

(10) CHECK VALVE Every ROLAIR air compressor is built with a check valve to seal off and maintain tank pressure after the top end pressure setting of pilot valve or pressure switch is reached. The check valve works in conjunction with the pressure switch relief valve to provide a *loadless* start for the compressor system. A quick burst of air escaping from the pressure switch relief valve after an electric unit reaches top end indicates the check valve is working properly. If the compressor has a mysterious leak after stopping that cannot be traced elsewhere, the check valve may require servicing/replacing.

(11) BREATHER/OIL FILL PLUG All reciprocating air compressor pumps are built with a crankcase vent to relieve the pressure that is created by the downward movement of the piston in the pump cylinder. Our direct-drive air compressors vent the crankcase pressure through special ports in the dipstick. Our belt-drive units vent through the oil-fill plug. Never operate the air compressor without the dipstick or oil-fill plug.

(12) AUTOMATIC-IDLE CONTROL Every ROLAIR gas-powered air compressor is built with an engine idle control kit that automatically decreases the engine speed when the top end pressure setting of the pilot unloader valve is reached. The top RPM setting of the engine is factory set for maximum performance and service life. Do not alter the factory top RPM setting. The engine idle speed is factory set and controlled by a black plastic Philips head screw on the carburetor. A slight increase to the idle speed setting may be required when operating in colder temperatures. Turn screw clockwise in 1/4 turn increments to increase the idle speed. If the idle speed setting is too low, premature fouling of spark plug will occur.

(13) COLD-START VALVE Most ROLAIR direct-drive air compressors are built with an automatic cold-start valve that allows the motor/pump to warm up before being subjected to tank pressure. Our belt-driven portable units have a manual drain valve installed on the pump aftercooler to assist with cold weather starting. Open drain valve and allow the motor and pump to run *unloaded* for a minute to warm up. Close the drain and repeat the procedure if the motor or engine continue to struggle.

(14) SCHMIDT BELT-TIGHTENING DEVICE (FOR GAS UNITS ONLY) Every ROLAIR gas-powered belt-driven portable air compressor has a unique system for maintaining proper belt tension. Simply loosen the 1/2" locknuts (only until washers beneath spin freely) that secure the engine and rotate the fine thread bolt located on the wheel end of the base plate clockwise until the desired belt tension is achieved. (See drawing in section on operating instructions for proper tension) Re-tighten 1/2" locknuts to secure engine and maintain desired belt tension setting.

(15) VIBRATION DAMPENER(S) The rubber pads installed beneath every portable ROLAIR tank assembly are very important to the proper operation of the air compressor. They provide protection from vibration that left unchecked could cause damage to many system components.

(16) ENGINE KILL SWITCH A kill switch is installed to easily stop the engine. Do not attempt to move the throttle lever (as described in the Honda owner's manual) when stopping the engine. The engine throttle lever is factory set and locked down at a top RPM setting that will provide maximum performance and service life for the complete air compressor system. The kill switch must be moved to the "On" position prior to pulling the recoil rope assembly to start the engine.

(17) ENGINE CHOKE Moving the choke lever completely to the left (closed position) will help start a cold engine. Also see instructions for cold-start valve (Item #13). After start up, the choke lever must be moved completely to the right (open position) for the engine to operate properly. Fouling of spark plug and excessive internal carbon build up will occur if engine is operated with choke lever even partially closed.

(18) FUEL SHUT-OFF VALVE The fuel shut-off valve should only be moved to the "Open" position (completely to the right) when the engine is being operated. Always stop the flow of fuel by moving the shut-off valve completely to the left when the engine is not being operated. Do not move or transport the air compressor with the fuel valve in the open position.

PRE-START CHECKLIST

Read the owner's manual thoroughly. Make sure that you completely understand all of the safety warnings, system controls and instructions provided before attempting to operate this air compressor. Every effort has been made to provide you with the information needed to obtain many years of reliable and trouble-free service out of your new air compressor. It is your responsibility to operate the air compressor properly. To obtain the longest possible service life from your air compressor you must always keep the following instructions in mind.

1. ALWAYS OPERATE THE COMPRESSOR IN A LEVEL POSITION

All splash-lubricated pumps have a dipper on the bottom of the connecting rod that must remain submerged in the oil bath. Operation at more than a 10 degree angle will cause the pump to seize and void the product warranty

2. OPERATE IN A CLEAN, DRY AND WELL VENTILATED AREA

Allow at least 18" behind the belt guard for proper cooling of pump from flywheel blast. Do not operate in the rain or in areas of standing water. Never operate in an area where other gases, fumes or vapors are present which may become explosive when compressed. Do not operate compressor in an enclosed area.

3. CHECK OIL LEVEL DAILY AND CHANGE AT REGULAR INTERVALS

Refer to the maintenance section of this owner's manual for the correct type/weight of oil to use and how often the oil should be changed. Check oil levels daily.

4. INSPECT/CLEAN/CHANGE INTAKE ELEMENTS ON A REGULAR BASIS

The ingestion of dirt into the pump and engine is the primary cause of premature wear. Pay special attention to the intake filters. Check intake filters daily.

5. USE LONGER PROPERLY SIZED AIR HOSE RATHER THAN EXTENSION CORDS

If an extension cord must be used, please refer to the chart below for the proper gauge and maximum length that can be used. The use of inadequately sized air hose will also lead to frictional pressure drops that could affect the proper performance of your air tools.

6. DO NOT USE A GENERATOR AS THE POWER SOURCE

Air compressors use inductive motors that require 3-5 times the full-load amp draw to properly start. Most generators will not provide the wattage needed to properly start this type of electric motor.

7. CHECK TENSION OF BOLTS, BELTS, AND HARDWARE ON A REGULAR BASIS

Operation of any equipment with loose bolts and/or fittings will lead to excessive vibration and the premature failure of the compressor system control components.

8. MAINTAIN RUBBER VIBRATION PADS

Excessive vibration is a major cause of premature compressor failure. Always maintain the rubber vibration pads located beneath tank assembly. Operation without them will void your warranty.

9. DRAIN MOISTURE FROM AIR TANKS DAILY

Water is a natural byproduct of compressed air. Drain air tank(s) after each use to combat internal tank corrosion. Keep drain valve(s) closed if storing compressor for any length of time.

ELECTRIC EXTENSION CORD TABLE

Minimum Wire Size		
Extension Cord Length	Motor 1/2 and 3/4 HP	Motor 1, 1-1/2, and 2 HP
Up to 25 ft.	14 Ga.	12 Ga.
25 – 50 ft.	12 Ga.	10 Ga.
50 – 100 ft.	10 Ga.	8 Ga.

- 10. DO NOT ALTER FACTORY RPM SETTINGS ON GAS-POWERED COMPRESSORS.** Engine throttle arm is factory set and locked into position at RPMs that will provide maximum performance, fuel consumption and service life. Alterations to this setting will void your warranty.

OPERATION

WARNING — Your safety and the wellbeing of others during the operation of every ROLAIR compressor is our main concern. Do not operate or permit anyone else to operate your air compressor until the information contained in this manual is read and completely understood. Please contact your distributor or our customer service department if you have any questions on the proper use of your air compressor.

DIRECT-DRIVE ELECTRIC

Establish that the air compressor is ready to operate by reviewing the topics and information provided in the “Pre-Start Checklist” section of this manual. Slowly open tank drain to remove any condensate that has accumulated and keep drain open for a few seconds after starting to warm up motor/pump assembly. Make sure the pressure switch lever is in the “Off” position before plugging power cord into a properly grounded outlet. Move pressure switch lever to the “On/Auto” position to build and automatically maintain top end tank pressure setting. Rotate regulator adjustment knob counterclockwise until the gauge attached reads 0 PSI before attaching air hose and accessory. Set working pressure by rotating regulator adjustment knob clockwise and lock in working pressure according to specifications provided by the tool manufacturer. Always use the pressure switch “On(Auto)/Off” lever to start or stop the air compressor. **Never** stop the compressor by unplugging it from the power source. Store compressor in a warm/dry location and perform maintenance as indicated in manual.

BELT-DRIVE ELECTRIC

START/STOP OPERATION:

Follow same procedures described above for use of direct-drive electric compressors. Open drain valve located on pump aftercooler for cold starting purposes. An electric belt-driven motor should not be subjected to more than 15 starts per hour. Consult your dealer or any authorized ROLAIR service center for information on a conversion kit if you experience nuisance tripping of the motor overload due to an excessive amount of motor starts per hour.

CONSTANT-SPEED OPERATION:

Constant speed or continuous-running operation should be used during periods of heavy use to extend motor life and prevent overheating. If your machine is built to only operate continuously, special care must be taken to safely start and stop the machine. Always shut off the power to the electrical outlet at the main breaker or optional on/off switch before plugging in or unplugging the power cord. We also highly recommend complete draining of storage tank(s) and opening of aftercooler drain valve prior to starting, especially when operating in cold temperatures. **Never** stop the compressor by pulling the plug from the outlet. Use the breaker or optional on/off switch to shut off the power to the outlet first.

DUAL-CONTROL OPERATION:

Dual controls allow an easy transition between start/stop and continuous-running operation. See figure 1 for instructions to switch operation from start/stop to constant speed. Always flip the lever on the pressure switch to the “off” position before plugging in or unplugging the power cord.

GAS POWERED

Refer to item numbers 12, 16, 17 & 18 in the “System Controls” section of this manual for information on the engine automatic idle control, kill switch, choke and fuel shut-off valve. Also note the engine throttle arm is locked into a top RPM setting that will provide maximum service life and does not need to be moved to start or stop the machine. Additional instructions can be found in the engine owner’s manual. Use the drain valve located on the pump aftercooler or intercooler for cold-starting purposes. Take additional care to keep dirt/debris from entering the fuel tank or obstructing the air flow through the engine or past the pump. Make sure the air flow to the regulator is completely closed (gauge attached reads 0 PSI) before attaching air hose and accessory. A slight *hissing* noise caused by the air flow being directed to atmosphere during engine idle is normal. Store compressor in a warm/dry location and perform maintenance as indicated in your manuals.

Figure 1

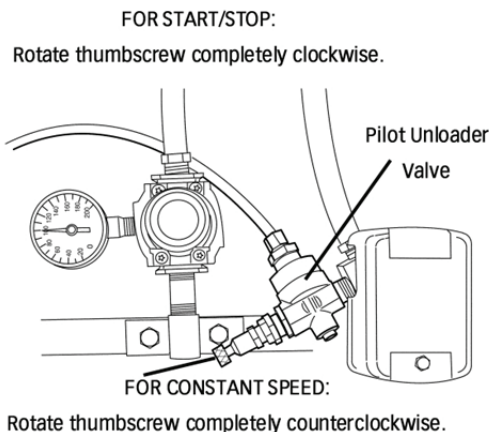

MAINTENANCE

Your new air compressor represents the finest engineering and construction available. Even the best machinery requires periodic maintenance. Please stick to the maintenance schedule and consider the suggestions that follow to keep your compressor in peak condition.

NOTE: Always unplug or shut down your compressor and drain the air tanks completely before attempting any type of maintenance. Wait for compressor to cool before servicing.

IMPORTANT: Replace the oil after the first 50 hours of operation.

MAINTENANCE HINTS:

- 1) Use a soap/water solution to check for air leaks.
- 2) Never clean filters with a flammable solvent.
- 3) Retorque head bolts only after pump has cooled.
- 4) Move motor 1/4" and roll belts back on to increase belt tension on electric units.
- 5) Never weld on air tank(s).
- 6) Use heat to loosen Loctite seal on drain valves, engine pulleys, and flywheels before attempting to remove.

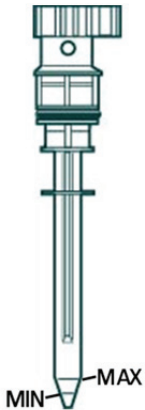

LUBRICATION

Prior to each use, make a habit of checking the pump oil level. Most direct-drive air compressors have a dipstick with casting marks that indicate the minimum and maximum acceptable levels of oil. Our belt-driven pumps have a sight gauge, located on the outside of the crankcase, to make the task even easier. Always maintain the oil level at the maximum mark on the dipstick or to 2/3 full in the sight gauge

Do not operate the pump with an inadequate or excessive amount of oil. The cost of failures which occur due to incorrect oil levels will not be covered under warranty.

DO NOT USE A DETERGENT OIL!

NOTE: Unit must be level when in operation

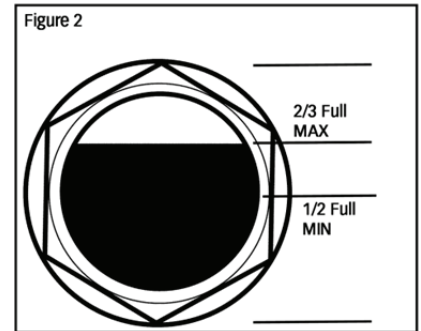

OIL TYPE TABLE

Temperature	0-40°	40° & Above
NON-DETERGENT – Straight Weight	10WT*	30WT*
*For maximum performance and service life, we recommend using ROLAIR Premium Quality compressor oil.		

MAINTENANCE SCHEDULE

Recommendation	Daily	Weekly	Monthly	Quarterly
Check Oil Level	X			
Drain Moisture from Tank(s)	X			
Inspect Air Filter(s)	X			
Check for Unusual Noise or Vibration	X			
Inspect Belt Guard	X			
Check for Air or Oil Leaks	X			
Clean Exterior of Air Compressor		X		
Check Condition of Vibration Pads		X		
Tighten/Retorque Bolts		X		
Check Belt Tension		X		
Check Operation of Safety Valve		X		
Change Compressor Oil			X	
Clean/Change Air Filter			X	
Perform Pump Up Time Test			X	
Check Operation of System Controls				X
Check Air Tanks for Dents/Leaks				X

TORQUE CHART (INCH/LB)

Pump Type	Direct Drive	K12	K17	K18	K24	K28	K30
Head Bolts	96	243	243	243	243	347	347
Cylinder Bolts	120	182	182	182	182	330	330
Bearing-Carrier Bolts	N/A	130	130	130	130	130	130
Connecting-Rod Bolts	N/A	121.5	121.5	121.5	121.5	121.5	173.6
Flywheel	N/A	243	382	382	382	477	477

Determine pump type using suffix of Model number (Example: 4090HK17 uses K17 pump)

PILOT VALVE ADJUSTMENT

RESETTING DIFFERENTIAL (2)

Make sure the top toggle lever is positioned as shown. (See Figure 3). Loosen locknut (1) by turning counterclockwise several full turns. Gently turn differential setting (2) clockwise only until the internal rod makes contact with the steel ball inside. After making contact, turn differential (2) counterclockwise 1/4 turn. Secure position by tightening locknut (1) and proceed to top end setting.

TOP END SETTING (4)

Loosen locknut (3) by turning counterclockwise several full turns. (4) is the top end setting. Turning (4) clockwise will increase the top end pressure setting. Turning counterclockwise will decrease the top end pressure setting. Begin at a low setting by turning counterclockwise one full turn. Proceed to fine tuning instructions.

FINE TUNING INSTRUCTIONS

Start engine/motor and observe tank pressure gauge. As tank pressure approaches 100-130 P.S.I.G., the pilot valve should begin unloading at felt muffler and cause gas engine to slow down to idle speed. If pilot valve does not unload as tank pressure approaches 130 P.S.I.G., slowly turn top end setting (4) counterclockwise until pilot starts to unload prematurely (at 100 P.S.I.G.), turn top end setting (4) clockwise in 1/4 turn increments, tap down on the internal rod at toggle attachment and repeat until desired top end setting is reached. If pilot valve begins to rattle (sputter), fine tune differential setting (2) 1/16 turn in either direction until rattling stops. After fine tuning, secure setting by turning locknuts (1 & 3) clockwise until tight. Hold setting (2 & 4) in place while turning locknuts to secure.

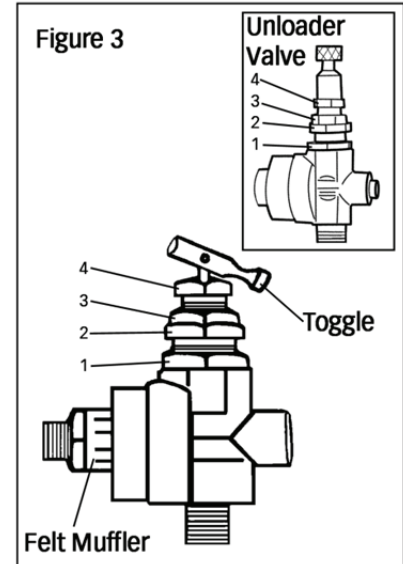

SCHMIDT BELT-TIGHTENING DEVICE (FOR GAS UNITS ONLY)

To tighten belt tension, proceed as follows:

1. Loosen locknuts for engine hold-down bolts only until washers beneath spin freely.
2. Rotate 1/2" adjusting bolt clockwise until desired tension is reached. (See Figure 4).
3. Retighten locknuts to secure engine.

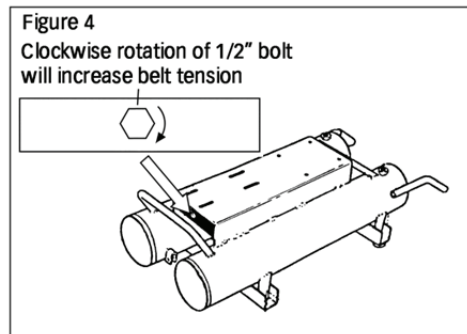

DRIVE PULLEYS

Drive pulleys must be properly aligned and drive belt tension set to specification. Improper pulley alignment and belt tension can cause motor overloading, excessive vibration and premature belt and/or bearing failure. (See Figure 5).

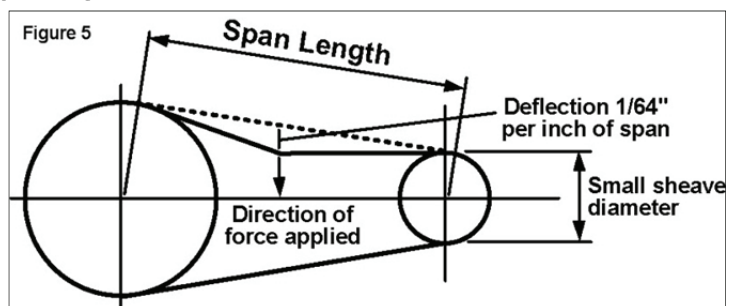

GASOLINE ENGINE RPM SETTINGS

Model	Top RPM	Idle RPM	Pump RPM
4090 Series	2950	1900	1025
1040 & 2040 Series	2775	1900	1175
6590 Series	3150	1900	1125
8422 & 8230 Series	3000	1900	900

NOTE: Engine RPM's (High – Low Settings) are factory set for maximum efficiency. Adjusting RPM's above factory specification will void the warranty.

TROUBLESHOOTING

WARNING - Make sure you completely understand all of the safety warnings and operation of each system control component before attempting any maintenance or repair. Always drain the tank pressure completely, make sure the power cord is unplugged, and unit has time to cool before performing any maintenance or service operations.

PROBLEM	CAUSE	SOLUTION
Pump is slow to build tank pressure	Loose/slipping belt	Adjust belt tension
	Excessive leaks in system	Correct air leaks
	Blown gasket	Replace head gaskets
	Broken reed valve	Replace reed valves
	Obstructed intake filter	Clean or replace intake element
	Leaking regulator	Replace regulator
	Defective pilot valve	Replace pilot valve
Excessive oil consumption	Too much oil in crankcase	Drain to proper level
	Improper weight of oil	Replace with proper oil
	Obstructed crankcase vent	Replace dipstick or oil fill plug/crankcase vent
	Dirty/plugged intake filter	Clean/replace intake filter
	Worn piston rings	Take unit in for service
Knocking noise	Scored cylinder	Take unit in for service
	Loose pulley or flywheel	Tighten appropriate parts
Overheating compressor	Loose belts	Adjust belt tension
	Internal pump problem	Take unit in for service
	Poor ventilation	Relocate compressor
Electric motor dead, will not even hum	Improper pump rotation	Contact an electrician
	Internal pump problem	Take unit in for service
	Thermal overload tripped	Locate and push reset button
	Reset physically broken	Replace overload/reset
Motor trips overload/reset button	Loose motor leads or electrical connection	Locate and correct loose electrical connection(s)
	Short in power cord	Replace power cord
	Motor is starting/stopping excessively	Install constant speed or dual control kit
	Overload is defective/weak	Replace overload
	Improper gauge of extension cord	Use longer lengths of air hose or heavier cord
Gasoline engine is hard to start	Stripped or poorly tightened motor thru bolts	Retighten or replace stripped thru bolts
	Cracks in end bell or housing	Take unit in for service
	Fouled, incorrect, or improperly gapped spark plug	Install proper spark plug after gapping to factory specs
	Improper engine oil level	Fill to top of threads for oil plug
Gasoline engine is hard to start	Improper weight of pump or engine oil	Change to proper weight of oil for operating temperature
	Improper or old gas	Take unit in for service



Guarantee

Associate Engineering Corporation warrants that all ROLAIR compressors will be free of defects in material and workmanship for a period of twelve months from the date of initial retail purchase, or eighteen months from the date of manufacture, whichever may occur first.

Should any failure to conform to this warranty be reported to the company within said period, the company shall, upon purchaser shipping the compressor to our plant transportation prepaid, correct such nonconformity by suitable repair or, at its option, furnish a replacement part F.O.B. our plant.

Associate Engineering Corporation shall not be liable for any unauthorized repairs, replacements, adjustments to the compressors, or the costs of labor performed by the purchaser.

This warranty is expressly in lieu of all other warranties expressed, implied or statutory (including, but not limited to, warranties of merchantability and fitness for purpose) and of any other obligations, and/or liabilities on the part of Associate Engineering Corporation. Associate Engineering Corporation neither assumes nor authorizes any other person to assume for it any other obligations or liability in connection with or with respect to any compressor.

Associate Engineering Corporation shall in no event be liable neither for any consequential, incidental or special damages nor for the improper selection of any compressor for a particular application.

Quality

Associate Engineering Corporation is devoted to continual quality control and thorough research of the products we build. It is our creed to give you, the user, all of the experience and engineering available in the production of every piece of equipment we produce.

Our line covers the complete needs of today's varied air requirements. Rely on ROLAIR for all the newest and finest features that are available for the modern compressor.



ROLAIR

SCHEMATIC FOR MODELS

6590HK18

6590RK18

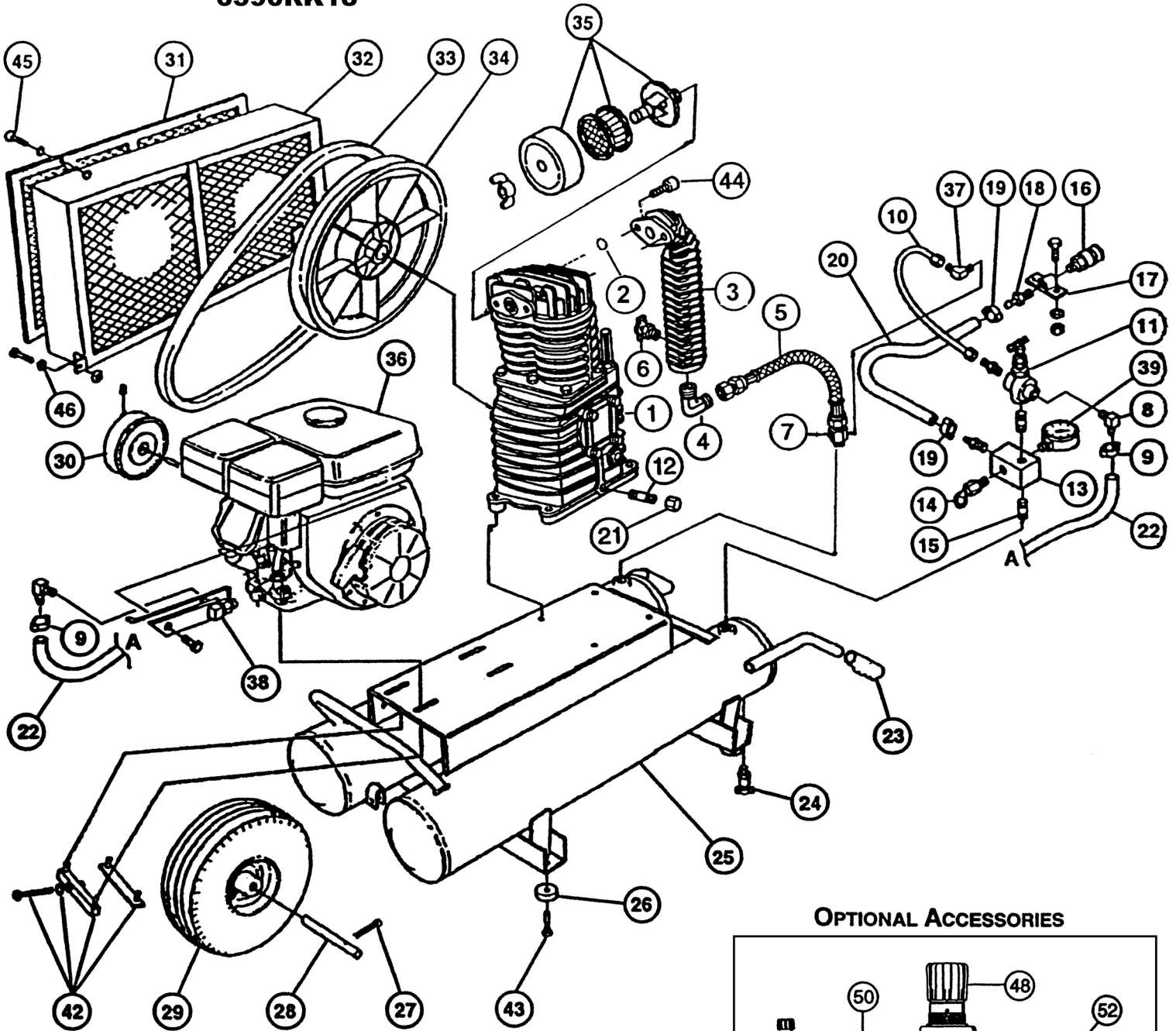

OPTIONAL ACCESSORIES

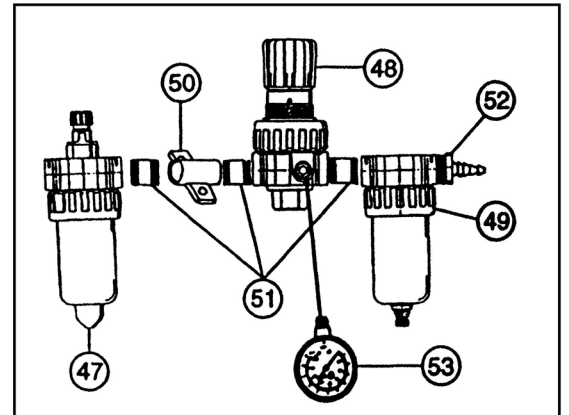

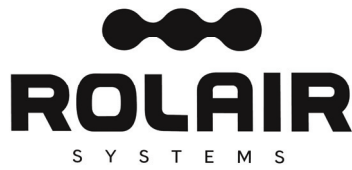

**PARTS LIST FOR MODELS
6590HK18 6590RK18**

Schem #	Description	Part #	Qty.	Schem #	Description	Part #	Qty.
1	Twin Cylinder Pump with Flywheel	PMP12K18CH	1	26	Rubber Foot	219	4
				27	Cotter Pin	181A	2
	Twin Cylinder Pump less Flywheel	PMP12K18CHLF	1	28	Axle	181	1
				29	Fully-Pneumatic Tire w/Sealant	WLS30SEAL	1
2	O-Ring	30502510CH*	1	30	Pulley	PUAK44X0750	1
3	Aftercooler	3290146ACH	1	31	Belt Guard Cover	BG9145	1
4	Brass Elbow	145D	1	32	Belt Guard Base	BG9140B	1
5	Braided Discharge Tube	145F	1	33	Belt	BT4L510	1
6	Drain Valve	132	1	34	Flywheel	31007280CH	1
7	Check Valve	CV4X4TA	1	35	Silencer/Filter Assembly	FS14050	1
8	Brass Elbow	BREL0250X0125H16	1		Filter Element – Replacement for Above	431	1
9	Hose Clamp	177	2				
10	1/4" Nylon Tube – 14.4"	178D	1.2'	36	Honda Engine	ENG06H01	1
	Brass Nut	BRNT0250	2		Optional Engine Drain Extension for Above	HDE5	1
	Brass Sleeve	BRSL0250	2		Robin Engine	ENG06R01	1
	Brass Ring	BRRG0250	2				
11	Pilot Unloader Valve	131B	1	37	Brass Elbow	BREL0250X012539	1
	Felt Muffler	131BM	1	38	Throttle Control Kit	192EGX160K1QX	1
	Retainer Ring	131BR	1	39	Gauge	GA0250200GC	1
12	Nipple	BLNP0250X1500	1	42	Belt Tightener/Mounting Kit	SPT5HP-ANGLE**	1
13	Aluminum Block Manifold	154	1	43	Screw	MIS10008	4
14	Safety Relief Valve	SRV0250N165	1	44	Bolt	37302530CH	2
15	Nipple	BLNP0500X1500	1	45	Spinlock Bolt	MIS10094	5
16	Quick Disconnect	309A	1	46	Bolt	MIS10022	2
17	Accessory Bracket	210	1		Lock Washer	MIS10099	2
18	Brass Coupler	BRCP0375X0375H12	2		Washer	MIS10108	2
19	Hose Clamp	177A	2	(Accessories)			
20	3/8" Rubber Hose - 16"	178A	1.34'	47	Lubricator	LUB0375	1
21	Cap	BLCA0250	1	48	Regulator	REG0375	1
22	1/4" Rubber Hose – 36"	178	3.0'	49	Filter	FIL0375	1
23	Handle Grip	328	2	50	Accessory Bracket	210	1
24	Drain Valve	132BV	2	51	Nipple	BLNP0375X1500	3
25	Twin Tank Assy – Honda	TNKASY6590H	1	52	Brass Coupler	BRCP0375X0375H12	1
	– Robin	TNKASY6590R	1	53	Gauge	GA0250200GC	1

*For units built prior to February 2000, order gasket 30501490CH

**For units built prior to February 2005, order SBT5HP-SQUARE



ROLAIR

SCHEMATIC FOR PMP12K18

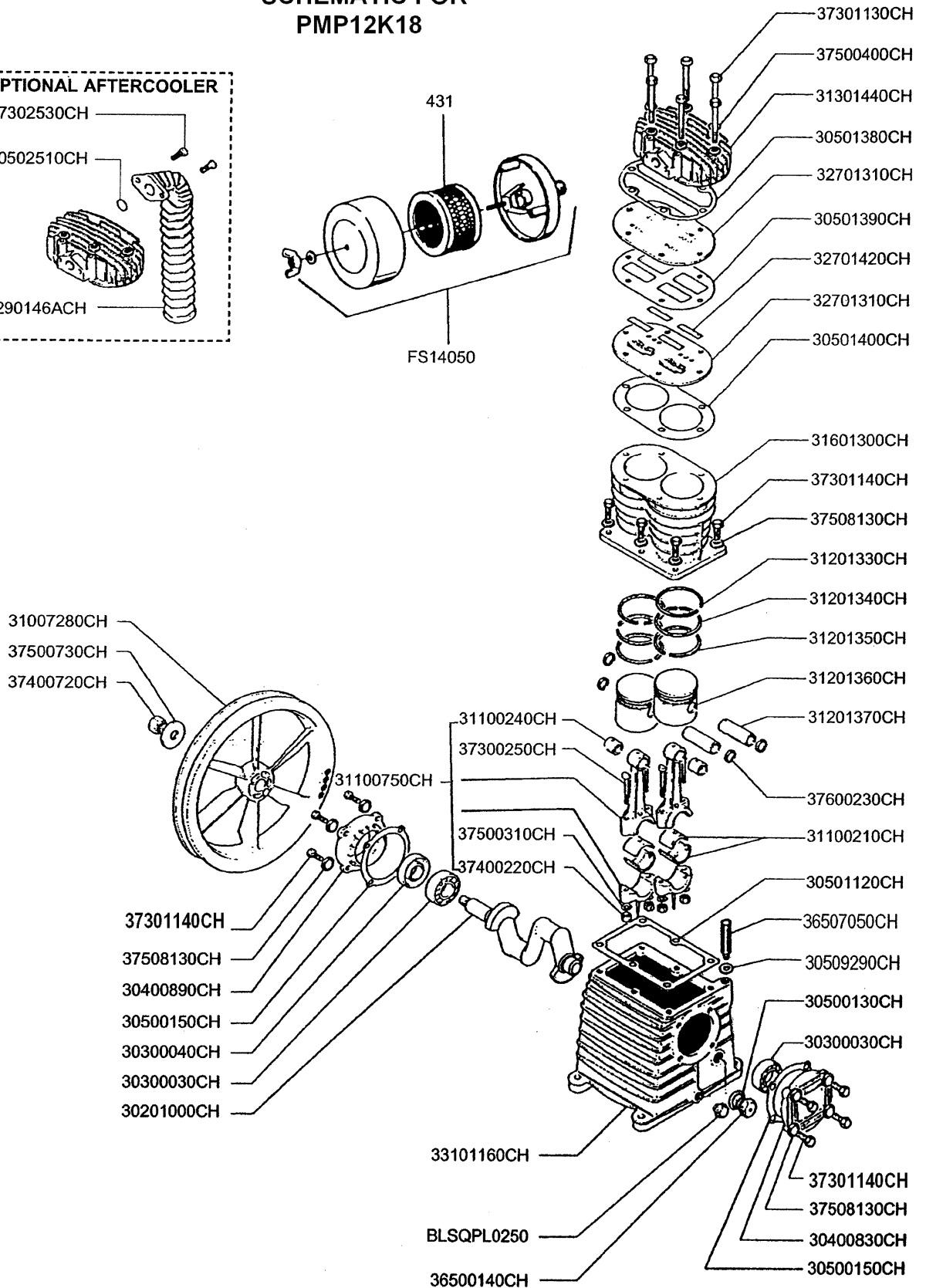
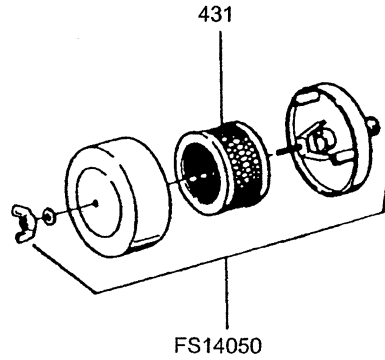
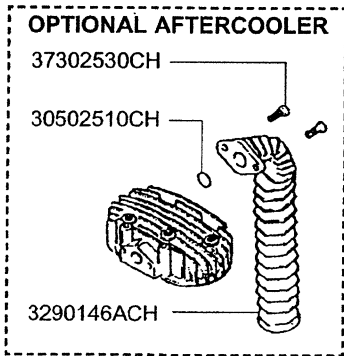

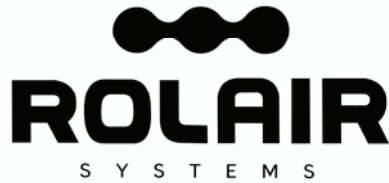

PARTS LIST FOR PMP12K18

Description	Part #	Qty.	Description	Part #	Qty.
Crankshaft	30201000CH	1	Valve	32701420CH	4
Bearing	30300030CH	2	Crankcase	33101160CH	1
Oil Seal	30300040CH	1	Sight Gauge	36500140CH	1
Bearing Carrier	30400830CH	1	3/8" Breather/Oil Fill	36507050CH	1
Bearing Carrier	30400890CH	1	Plug		
Gasket	30500130CH	1	Bolt	37300250CH	4
Gasket	30500150CH	2	Bolt	37301130CH	6
O-Ring	30509290CH	1	Bolt	37301140CH	6
Gasket	30501120CH	1	Nut	37400220CH	4
Gasket	30501380CH	1	Nut	37400720CH	1
Gasket	30501390CH	1	Washer	37500310CH	4
Gasket	30501400CH	1	Washer	37500400CH	6
Flywheel	31007280CH	1	Washer	37500730CH	1
Bearing Shell	31100210CH	2	Washer	37508130CH	14
Bushing*	31100240CH	2	Snap Ring	37600230CH	4
Connecting Rod w/Upper Bushing	31100750CH	2	Filter Element	431	1
Ring	31201330CH	2	Plug	BLSQPL0250	1
Ring	31201340CH	2	Silencer/Filter Assembly	FS14050	1
Ring	31201350CH	2	Ring Set	K18RINGS	1
Piston	31201360CH	2	Gasket Set	K18GASKETS	1
Piston Pin	31201370CH	2	Valve Plate Assembly	1800VK18	1
Head	31301440CH	1			
Cylinder	31601300CH	1			
Valve Plate	32701310CH	2			
OPTIONS-			NOTE: Gasket for "old-style" Aftercooler	30501490CH	1
O-Ring	30502510CH	1			
Aftercooler	3290146ACH	1			
Bolt	37302530CH	2			

*Bushing is not machined to fit piston pin if ordered separate from connecting rod.

